

7-Series

ELECTRIC WALKIE PALLET TRUCKS

SPECIFICATIONS

7HBW23

Featuring SepEx™ Drive System Technology, Toyota's electric pallet trucks offer superior overall performance and reliability. Increased speeds with advanced ergonomics provide higher productivity, optimized operator comfort and efficiency.

Standard Features

PERFORMANCE

- 4500 lb capacity
- 24 volt electrical system
- Separately Excited (SepEx™) drive motor with thermal protection and current limiting
- SepEx™ Transistor Control System with MOSFET
- Class 'F' motor insulation
- Controller area network (CAN-Bus) communication
- Regenerative braking
- Contactor-less drive controls
- Electronic touch-pad, keyless entry system with password protection
- Programmable performance for up to ten operators
- Electronic raise and lower controls in operator handle
- Auto-off system
- Error indicator with self-diagnostics
- Fault code memory with hour meter reading
- Hour meter indicator
- Programmable service indicator
- Battery discharge indicator with lift interrupt
- Anti-roll system
- Resetting circuit breaker
- Fused control and power circuits

BODY/EXTERIOR DESIGN

- Box rail fork construction
- Tapered fork tips with pallet entry slides
- Polyethylene stability wear pads (reversible)
- Chrome-plated lift cylinder, 2" dia.
- Rubber drive tire, 10" dia. X 5"
- Polyurethane load wheels, 3.25" dia. X 4.5"
- Battery compartment (26.5" X 7.8" X open height)
- SB-175 battery connector (red)
- One-piece lift-off service access cover with pen & pencil storage tray
- Steel fixed pull rods
- Electric horn

OPERABILITY & ERGONOMICS

- Multifunction control handle with ergonomically angled hand grips
- Fingertip control of all functions
- Directional thumb wheels
- Programmable neutral speed reduction (coast control)
- Direction reverse switch on control handle
- Low speed torque
- Spring-loaded control handle
- "Pinwheel" capability for right angle stacking

- Electric disc brake
- Emergency power disconnect switch
- Battery disconnect handle

Optional Equipment

- 48" high load backrest (removable)
- 60" high load backrest (removable)
- 72" high load backrest (removable)
- Battery compartment (26.5" X 9" X open height)
- Battery/charger pack (24V) swing-out tray (152 AH)
- Battery/charger pack (24V) maintenance-free (195 AH)
- Spring-loaded stabilizing casters
- Crowned poly drive tire
- Grip rubber drive tire
- Rubber non-marking drive tire
- Rubber traction drive tire
- Polyurethane drive tire
- Cold storage conditioning
- Corrosion conditioning
- UL approved model type E
- UL approved model type EE



7HBW23 Specifications

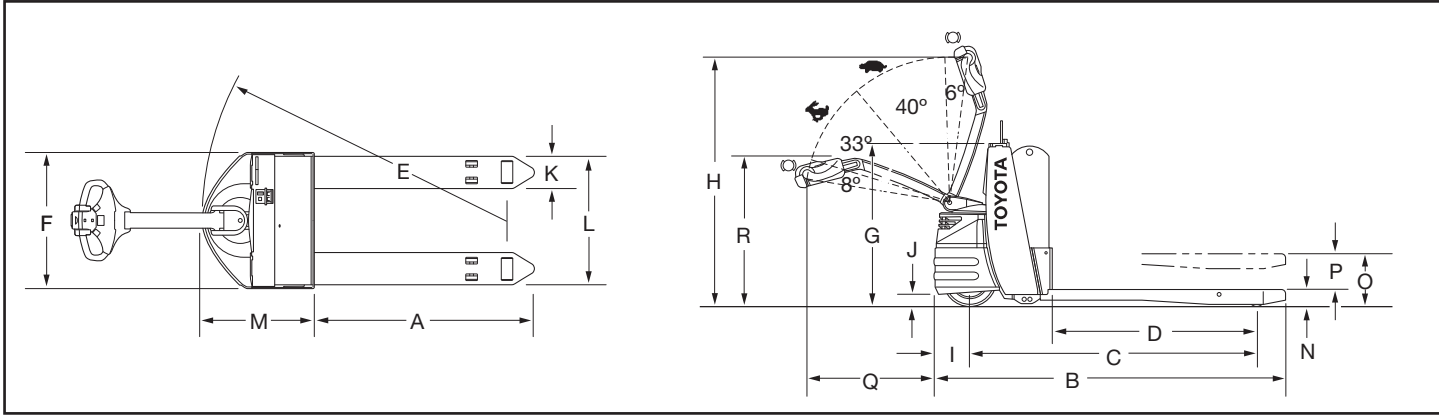

EXTERIOR DIMENSIONS – In (mm)

A	Fork Length (Actual)	in (mm)	29.5 (749)	33.5 (851)	39.5 (1003)	43.5 (1105)	45.5 (1156)	51.5 (1308)	57.5 (1461)
B	Overall Length	in (mm)	52.6 (1336)	56.6 (1438)	62.6 (1590)	66.6 (1692)	68.6 (1742)	74.6 (1895)	80.6 (2047)
C	Wheelbase (Lowered)	in (mm)	39.9 (1013)	43.9 (1115)	49.9 (1267)	53.9 (1369)	55.9 (1420)	61.9 (1572)	67.9 (1725)
C	Wheelbase (Raised)	in (mm)	36.8 (935)	40.8 (1036)	46.8 (1189)	50.8 (1290)	52.8 (1341)	58.8 (1494)	64.8 (1646)
D	Load Wheel Location (Lowered)	in (mm)	23.9 (607)	27.9 (709)	33.9 (861)	37.9 (963)	39.9 (1013)	45.9 (1166)	51.9 (1318)
D	Load Wheel Location (Raised)	in (mm)	20.6 (523)	24.6 (625)	30.6 (777)	34.6 (879)	36.6 (930)	42.6 (1082)	48.6 (1234)
E	Turning Radius	in (mm)	46.9 (1191)	50.9 (1293)	56.9 (1445)	60.9 (1547)	62.9 (1598)	68.9 (1750)	74.9 (1902)
F	Overall Width	in (mm)	28 (711)						
G	Power Unit Height	in (mm)	31.2 (792)						
H	Control Handle Height	in (mm)	47.9 (1217)						
I	Bumper to Drive Tire Center	in (mm)	7.0 (178)						
J	Bumper Underclearance	in (mm)	2.2 (56)						
K	Fork Width	in (mm)	6.75 (171)						
L	Fork Overall Width (Actual)	in (mm)	17.5 (445) or 19.5 (495) or 21.5 (546) or 24.5 (622) or 26.5 (673)						
M	Head Length	in (mm)	23 (584)						
N	Fork Down Height	in (mm)	3.25 (83)						
O	Elevated Height	in (mm)	8.65 (220)						
P	Lift	in (mm)	5.4 (137)						
Q	Handle Length	in (mm)	25.9 (658)						
R	Lowered Handle to Floor	in (mm)	27.8 (706)						

Exterior dimensions have been given for a standard model with a 7.8" wide battery compartment.

PERFORMANCE

Travel Speed (mph)	Full Load	3.4
	No Load	3.6
Gradeability %	Full Load	6

TIRES

Type	Drive	Rubber
	Load	Polyurethane

BATTERY – 24 VOLT

Max Amp Hr		330
Battery Connector/Color		SB-175/Red
Battery Connector Cable Location		B
Battery Connector Cable Length		18
Battery Weight Max.		660
Battery Weight Min.		200
Battery Compartment (L x W) – Open Height	Standard	26.5" x 7.8"
	Optional	26.5" x 9"

aisle requirement – RIGHT ANGLE STACK

Model	7HBW23						
Load Width	Load Length (Nominal Fork Length)						
	32	36	42	46	48	54	60
in (mm)	in (mm)	in (mm)	in (mm)	in (mm)	in (mm)	in (mm)	in (mm)
40 (1016)	53 (1346)	57 (1448)	63 (1600)	67 (1702)	69 (1753)	75 (1905)	81 (2057)
44 (1118)	52.8 (1341)	56.8 (1443)	62.8 (1595)	66.8 (1697)	68.8 (1748)	74.8 (1900)	80.8 (2052)

Minimum Aisle Width for Right Angle Stacking

Aisle widths have been given for a standard model with 7.8" battery box. Add a minimum of 12" for maneuverability. Aisle widths assume a 1" clearance on each side of load.



Some product features described herein are optional. Please consult your dealer for specifications. Details of specifications and equipment are based on information available at time of printing and may change without notice.