

7-SERIES ELECTRIC



STAND-UP RIDER
COUNTERBALANCE
3,000 - 5,000 LBS
SPECIFICATIONS



3,000 – 5,000 lbs • Standard Features

PERFORMANCE

- 36 Volt electrical system
- Separately Excited (SEPEX) drive motors
- SEPEX transistor control system with MOSFET
- Separate independent lift, steer, & auxiliary motors
- Series wound lift motor
- Multifunction digital display
 - Time & Date
 - Multifunction hour meters
 - Battery discharge indicator w/lift interrupt
 - Brush wear & temperature indicators (on drive and lift motors)
 - Maintenance indicator
- Programmable performance parameters
- Poly steer tire
- Power hook up for onboard terminal
- UL-approved model type E

OPERABILITY

- Multifunction control handle
- Flexible side stance operator compartment
- High visibility mast & overhead guard
- Hydrostatic power steering
- Brake hold and stall protection
- Electric disc brakes
- Regenerative braking
- Proportional plugging

ERGONOMICS

- Spacious operator compartment
- ERGOMAT® cushioned floor and brake pedal
- Ergonomically sloped floorboard
- Low step height (8 inch)
- Low effort brake pedal
- Comfort-padded back and armrest
- Amenity tray
- Integrated clipboard

SERVICEABILITY

- One-piece top cover
- Self diagnostics with instructional messages
- Vertically mounted motors
- Fault code memory
- Built-in analyzer
- Programmable maintenance indicator
- Battery compartment rollers
- Battery retaining gates
- No directional contactors

OPTIONAL EQUIPMENT

- UL-approved model type EE
- 13.6 inch battery compartment
- 16.25 inch battery compartment
- Alternate material drive tire
- Sideshifter
- Cold storage conditioning
- Digital load weight display
- Fire extinguisher – 2.5 lb. dry chemical
- Custom mast heights
- Operator compartment fan
- Reverse steering
- 83 inch overhead guard
- Hinged rear operator guard
- Alternate backrest heights
- Auxiliary function
- Mechanical mast stop (FSV only)
- Lift limit with override (FSV only)
- Bottler's mast tilt
- Tapered forks
- Quick disconnects
- Strobe light
- Travel alarm
- Mast mounted work lights
- Rear work light
- Travel speed reduction above free-lift (FSV only)
- Special paint color, complete truck

Note: Please check with your local Toyota sales professional for additional options.

3,000 – 5,000 lbs • Specifications

Models		7BNCU15	7BNCU18	7BNCU20	7BNCU25
Load Capacity (with 24-in. load center)	lb	3000	3500	4000	5000
Brakes		Electric Disc Brakes			

EXTERIOR DIMENSIONS

A Maximum Fork Height (MFH) FSV Mast	in	188	188	188	188
B Mast Lowered Height	in	83	83	83	83
C Mast Extended Height	in	236	236	236	236
D Overhead Guard Height	in	88	88	88	88
E Battery Roller Height	in	7.5	7.5	7.5	7.5
F Load Backrest Height	in	48	48	48	48
G Carriage Width (Fork Spread)	in	35.5	35.5	35.5	35.5
H Chassis Width	in	41	41	42.88	42.88
I Chassis Height	in	50	50	50	50
J Fork Size (TxWxL)	in	1.5x4x42	1.5x4x42	1.5x4x42	1.5x4x42
K Load Distance	1) in	11.1	11.1	11.1	11.3
L Wheelbase	in	50.4	50.4	53.1	55.6
M Length to Fork Face	in	68.5	68.5	71.2	73.7
N Tilt Range	forward/backward	degrees	3°/5°	3°/5°	3°/5°
O Turning Radius	in	57.8	57.8	60.5	63
P Overhead Guard Post Spread	in	27.5	27.5	27.5	27.5
Q Freelift	in	35	35	35	35
R Step Height	in	8	8	8	8
S Underclearance	in	4	4	4	4
T Grade Clearance	%	32	32	31	29
U Basic Right Angle Stack	2) in	68.8	68.8	71.5	74

Battery Compartment	Width	in	38.5	38.5	38.5	38.5	
	Length	in	18.5	18.5	21.25	23.75	
	Height	in	32.3	32.3	32.3	32.3	
Power Type	Battery						
Battery	Voltage/Capacity (6-hour ratings)	36V	AH	1085	1085	1240	1395
	Min. weight		lb	2300	2300	2600	2700
Electric Motors	Drive (Dual)	36V	HP	5.6	5.6	9.3	9.3
	Load Handling (Hyd.)	36V	HP	7.2	7.2	7.9	7.9
Control Type	Drive	Transistor-MOSFET					
	Load Handling (Hyd.)	Contactor					

PERFORMANCE DATA

Maximum Travel Speed	fwd/rvs – full load	36V	mph	7.0	7.0	7.0	7.0
	fwd/rvs – no load	36V	mph	7.2	7.2	7.2	7.2
Maximum Lift Speed	full load	36V	fpm	70	65	60	50
	no load	36V	fpm	110	110	110	110
Maximum Lowering Speed	full load		fpm	100	100	100	100
	no load		fpm	80	80	80	80
Maximum Gradeability	full load		%	15	15	15	15
	no load		%	15	15	15	15

UNDERCLEARANCE

Center of Wheelbase	in	4	4	4	4
---------------------	----	---	---	---	---

TRUCK WEIGHTS

Gross weight without battery	lb	6950	7100	7250	7400
------------------------------	----	------	------	------	------

ATTACHMENT

Attachment Operating Hydraulic Pressure	psi	adjustable	adjustable	adjustable	adjustable
---	-----	------------	------------	------------	------------

Tires

Type (front/rear)		Solid Rubber/Poly	Solid Rubber/Poly	Solid Rubber/Poly	Solid Rubber/Poly
Size (ODxWxD)	Drive	16.25x6x11.25	16.25x6x11.25	16.25x7x11.25	16.25x7x11.25
	Steer	10x3.5	10x3.5	10x3.5	10x3.5

1) Centerline of front axle to front face of forks. 2) Add load length and aisle clearance.

3,000 – 5,000 lbs • Specifications

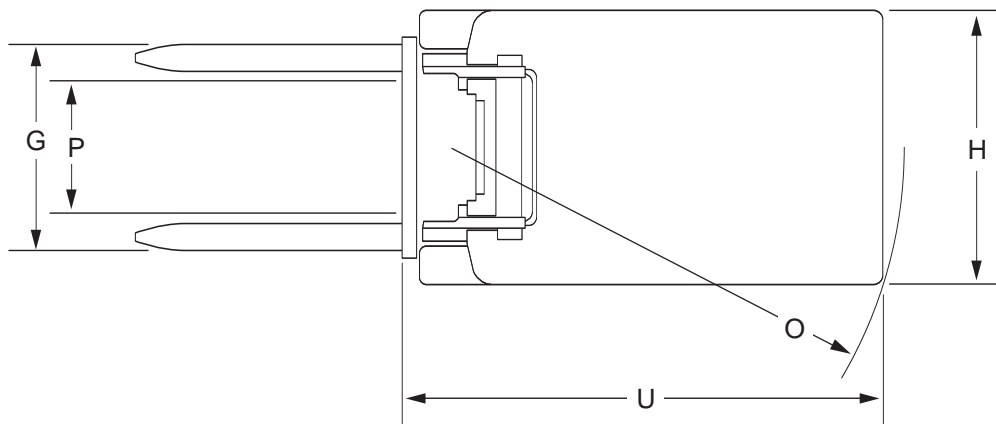
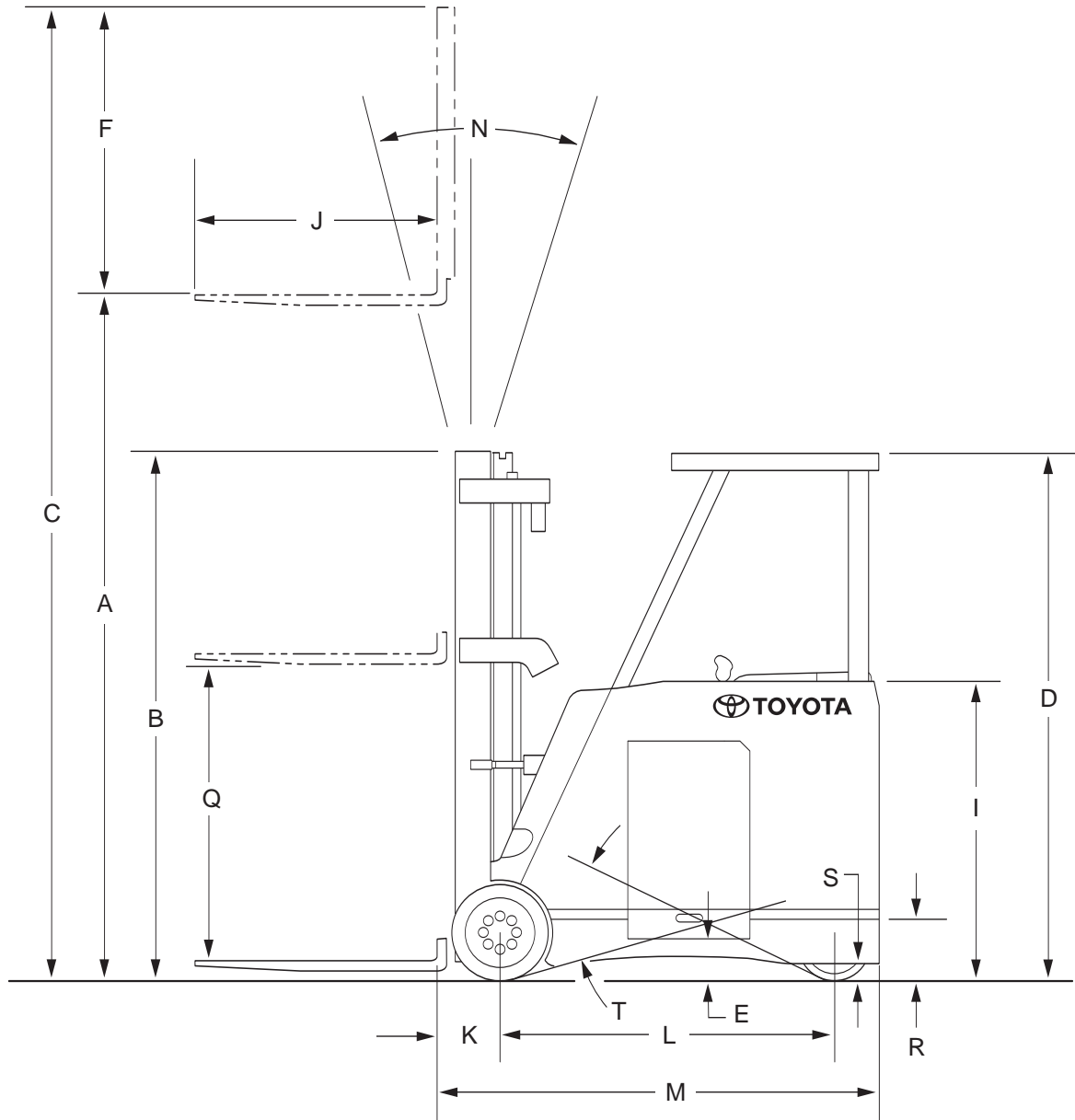

3,000 – 5,000 lbs • Mast Specifications

7BNCU15

Mast Type	Maximum Fork Height (top of forks)	Overall Height			Free Lift		Tilt Range		Standard Tread ⁽³⁾	Wide Tread ⁽⁴⁾
		Lowered	Extended		Without Load Backrest ⁽¹⁾	With Standard Load Backrest				
			Without Load Backrest ⁽¹⁾	With Standard Load Backrest			Without Load Backrest ⁽¹⁾	With Standard Load Backrest	FWD	BWD
		in	in	in	in	in	in	deg	deg	lb
2-Stage (FV)	127	83	151	175	59	35	3	5	3000	-
	137	88	161	185	64	40	3	5	3000	-
	152	95	176	200	71	47	3	5	3000	-
3-Stage (FSV)	188	83	212	236	59	35	3	5	3000	-
	203	88	227	251	64	40	3	5	3000	-
	227	99	251	275	75	51	3	5	3000	-
4-Stage (QFV)	251	107	275	299	83	59	3	5	3000	-
	223	77	247	271	53	29	3	5	-	3000
	241	83	265	289	59	35	3	5	-	3000
	259	89	283	307	65	41	3	5	-	2500
	271 ⁽²⁾	93	295	319	94	70	3	5	-	1950

Note: Height of standard load backrest is 48 in.

(1) This dimension is approximate. Dimension will need to be adjusted if any hoses or quick disconnects extend above the carriage.

(2) Must be ordered as a TSDR.

(3) Overall width is 41".

(4) Overall width is 44".

7BNCU18

Mast Type	Maximum Fork Height (top of forks)	Overall Height			Free Lift		Tilt Range		Standard Tread ⁽³⁾	Wide Tread ⁽⁴⁾
		Lowered	Extended		Without Load Backrest ⁽¹⁾	With Standard Load Backrest				
			Without Load Backrest ⁽¹⁾	With Standard Load Backrest			Without Load Backrest ⁽¹⁾	With Standard Load Backrest	FWD	BWD
		in	in	in	in	in	in	deg	deg	lb
2-Stage (FV)	127	83	151	175	59	35	3	5	3500	-
	137	88	161	185	64	40	3	5	3500	-
	152	95	176	200	71	47	3	5	3500	-
3-Stage (FSV)	188	83	212	236	59	35	3	5	3500	-
	203	88	227	251	64	40	3	5	3500	-
	227	99	251	275	75	51	3	5	3400	-
4-Stage (QFV)	251	107	275	299	83	59	3	5	2950	-
	223	77	247	271	53	29	3	5	-	3500
	241	83	265	289	59	35	3	5	-	3300
	259	89	283	307	65	41	3	5	-	2500
	271 ⁽²⁾	93	295	319	94	70	3	5	-	1950

Note: Height of standard load backrest is 48 in.

(1) This dimension is approximate. Dimension will need to be adjusted if any hoses or quick disconnects extend above the carriage.

(2) Must be ordered as a TSDR.

(3) Overall width is 41".

(4) Overall width is 44".

7BNCU20

Mast Type	Maximum Fork Height (top of forks)	Overall Height			Free Lift		Tilt Range		Standard Tread ⁽³⁾	Wide Tread ⁽⁴⁾
		Lowered	Extended		Without Load Backrest ⁽¹⁾	With Standard Load Backrest				
			Without Load Backrest ⁽¹⁾	With Standard Load Backrest			Without Load Backrest ⁽¹⁾	With Standard Load Backrest	FWD	BWD
		in	in	in	in	in	in	deg	deg	lb
2-Stage (FV)	128	83	152	176	59	35	3	5	4000	-
	140	89	164	188	64	40	3	5	4000	-
	152	95	176	200	71	47	3	5	4000	-
3-Stage (FSV)	188	83	212	236	59	35	3	5	4000	-
	203	88	227	251	64	40	3	5	4000	-
	227	99	251	275	75	51	3	5	3800	-
4-Stage (QFV)	251	107	275	299	83	59	3	5	3000	-
	223	77	247	271	53	29	3	5	-	3500
	241	83	265	289	59	35	3	5	-	3300
	259	89	283	307	65	41	3	5	-	3110
	271 ⁽²⁾	93	295	319	94	70	3	5	-	2800
	277 ⁽²⁾	95	300	324	96	72	3	5	-	2350

Note: Height of standard load backrest is 48 in.

(1) This dimension is approximate. Dimension will need to be adjusted if any hoses or quick disconnects extend above the carriage.

(2) Must be ordered as a TSDR.

(3) Overall width is 42.5".

(4) Overall width is 46".

3,000 – 5,000 lbs • Mast Specifications

7BNCU25

Mast Type	Maximum Fork Height (top of forks)	Overall Height			Free Lift		Tilt Range		Standard Tread ⁽²⁾
		Lowered	Extended		Without Load Backrest ⁽¹⁾	With Standard Load Backrest	FWD	BWD	Load Capacity @ 24-in. Load Center
			Without Load Backrest ⁽¹⁾	With Standard Load Backrest					
		in	in	in	in	in	deg	deg	lb
2-Stage (FV)	119	83	143	167	59	35	3	5	5000
	131	89	155	179	64	40	3	5	5000
	143	93	167	191	71	47	3	5	5000
3-Stage (FSV)	188	83	212	236	59	35	3	5	5000
	203	88	227	251	64	40	3	5	4800
	227	99	251	275	75	51	3	5	4100
	251	107	275	299	83	59	3	5	3000

Note: Height of standard load backrest is 48 in.

(1) This dimension is approximate. Dimension will need to be adjusted if any hoses or quick disconnects extend above the carriage.

(2) Overall width is 42.5".



Some product features described herein are optional. Please consult your dealer for specifications. Details of specifications and equipment are based on information available at time of printing and may change without notice.



Toyota is the number one selling lift truck in the United States.