

6-Series

ELECTRIC WALKIE STRADDLE STACKER

SPECIFICATIONS

6BWS11 - 2200 lbs

6BWS15 - 3000 lbs

6BWS20 - 4000 lbs

Toyota's walkie straddle stacker is a high performing, versatile, maneuverable and easy to use lift truck. It's the perfect solution for everyday material handling duties.

Standard Features

PERFORMANCE

- 2200 lbs capacity (6BWS11)
- 3000 lbs capacity (6BWS15)
- 4000 lbs capacity (6BWS20)
- 24 Volt electrical system
- MOSFET transistor control system
- Separately excited drive motor (SEM)
- UL-approved model type E
- On/off key switch
- Programmable performance
- Electronic raise and lower controls in operator handle
- Manual raise and lower controls
- Class 'H' motor insulation
- Oil-immersed power-train

BODY/EXTERIOR DESIGN

- 32" to 50" baseleg openings (inside dimensions) in 1" increments
- Electronic horn
- 32.3"x9" battery compartment (6BWS11)
- 32.3"x13.3" battery compartment (6BWS15.20)
- 30" wide ITA Class II fork carriage
- 42" fork length
- 48" load backrest extension
- Internal hose reeving

- Crowned poly drive tire, 10.5"x5"
- Tandem Polyurethane load wheels, 4"x2.875"
- Polyurethane caster wheels, 4"x2.5"
- Baseleg with tapered toe box
- Fully-hinged steel service access door
- Spring-loaded torsion bar suspension with stabilizing casters (6BWS15.20)
- Wide view 2-stage mast (V)
- Drive axle mounted string guards
- Pressure overload valve & lowering control fuses

OPERABILITY & ERGONOMICS

- Emergency power disconnect switch
- Automatic resetting circuit breaker
- Reverse polarity protection
- Mechanical drum brake
- Directional thumb control
- Safety glass mast guard
- Direction reverse switch on control handle
- Control handle with 8.5° ergonomic angle
- Power on self test with self-diagnostics

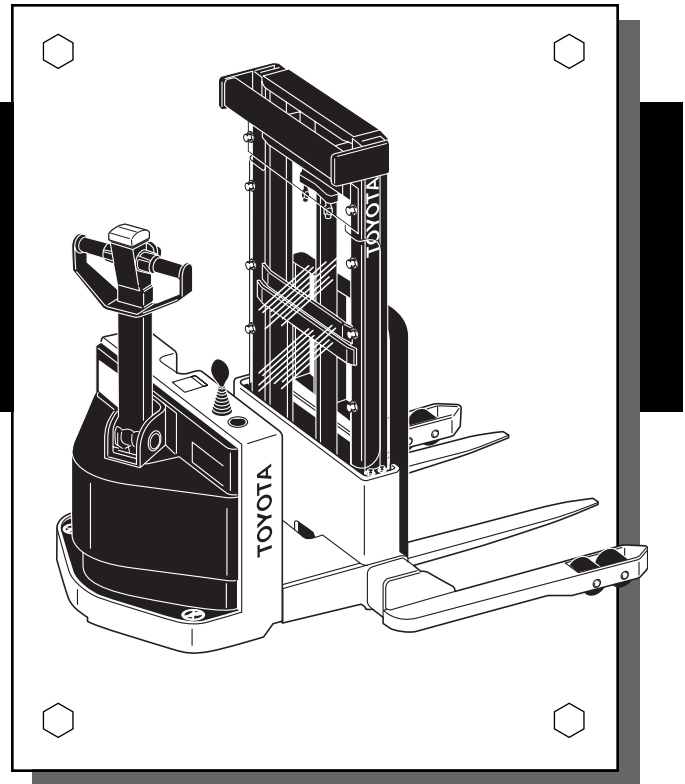

Optional Equipment

- Twist grip control handle in place of thumb control
- Hour meter
- Battery discharge indicator
- Combination battery discharge/hour meter indicator
- Combination battery discharge/hour meter indicator with lift interrupt
- Pallet centering guide
- UL-approved model type EE
- Corrosion conditioning
- Cold storage conditioning
- Audible travel alarm
- Battery compartment rollers
- Toggle switch in place of key switch
- Screen guard in place of safety glass mast guard
- Sideshifter
- 30", 36" or 48" fork lengths
- 36" or 44" load backrest extension
- Various drive tire compounds
- Various battery connectors
- Various strobe lights
- Various flashing beacons
- Wide view full free lift 3-stage mast (FSV)

6BWS11.15.20 Specifications

Models		6BWS11	6BWS15	6BWS20
Load Capacity (with 24-in. load center)	lb	2200	3000	4000
Brakes		Mechanical Drum Brake		

EXTERIOR DIMENSIONS

Carriage Width	in	30		
Basic Right Angle Stacking Aisle Width	in	See Chart		
A Maximum Fork Height (MFH)	in	128	124	
B Mast Lowered Height	in	83		
C Mast Extended Height	in	176	172	
D Free Lift	in	12	6	
E Wheelbase	in	51.1	55.4	
F Head Length (Length to Fork Face) V/FSV Mast	in	38.4/43.6	42.7/47.9	44.7/47.9
G Truck Length (Length to End of Base Legs)	in	67	71.3	
H Power Unit Width	in	34.1		
I Power Unit Height	in	32.5		
J Battery Roller Height	in	9.8		
K Base Leg Inside Dimension (ID) -1" Increments	in	32 to 50		
L Base Leg Outside Dimension (OD)-1" Increments	in	40 to 58		
M Base Leg Width	in	4		
N Fork Size TxWxL	in	1.5x4x42		1.75x4x42
O Fork Adjustment Min./Max.	in	8.5/30		
P Underclearance	in	2		
Q Outside Turning Radius	in	60.8	65.1	

DIMENSIONS OF BATTERY COMPARTMENT

R Battery Compartment LxW (open height)	in	32.3x9	32.3x13.3		
Total Weight	Without Battery	lb	2450	2585	2840
Power Type			Battery		
Battery	Voltage/Capacity (6-hour ratings) Max.	V/AH	24/330	24/650	
	Weight Min.	lbs	300	950	
Electric Motors	Drive (60 min)	hp	1.2		
	Load Handling (5 min 20%)	hp	4.8		
Control Type	Drive		Transistor		
	Load Handling		Electromagnetic Contactor		

PERFORMANCE DATA

Maximum Travel Speed	full load	mph	2.9	2.6
	no load	mph	3.3	3.2
Lift Speed	full load	fpm	32	27
	no load	fpm	49	
Lowering Speed	full load	fpm	60	
	no load	fpm	42	
Gradeability ¹⁾	full load/no load	% (tan θ)	6/10	

1) Trucks are designed for level floor operation. Represents ability to transverse short ramps when required.

TIRES

Type (Drive/Caster/Load)			Polyurethane
Size (dia. x width)	Drive	in	10.5x5
	Caster	in	4x2.5
	Load	in	4x2.875

AISLE REQUIREMENTS - RIGHT ANGLE STACKING

6BWS11			6BWS15			6BWS20		
Pallet Width	Load Length		Pallet Width	Load Length		Pallet Width	Load Length	
in	in	in	in	in	in	in	in	in
32	74	82	32	78	86	32	81	89
40	72	81	40	76	85	40	79	88
48	69	80	48	73	84	48	77	86

Aisle width requirements are based on 6" clearance between each side of the load.

Add a minimum of 6" to 10" for maneuverability.

Add a minimum of 6" for 3-stage mast for 6BWS11, 6" to 9" for 6BWS15 and 4.5" for 6BWS20.

DIMENSIONAL DRAWING

6BWS11.15.20

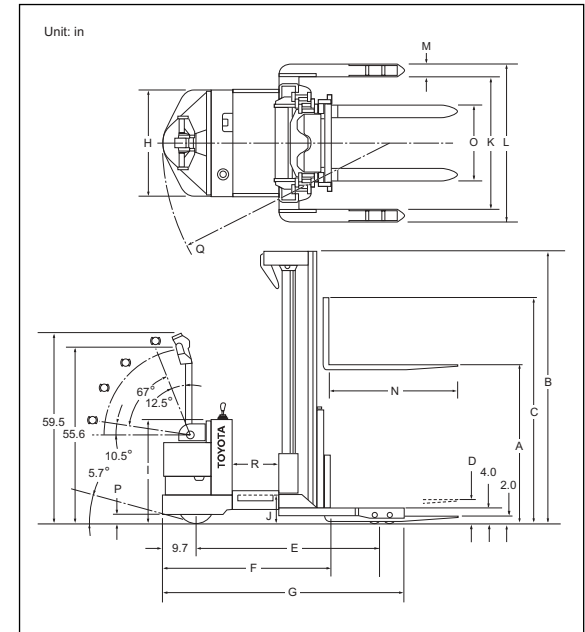

MAST SPECIFICATIONS & RATED CAPACITIES

6BWS11

Mast Type	Maximum Fork Height	Overall Lowered Height	Free Lift	Minimum Base Leg (ID)	Capacity @ 24 in LC
V	in	in	in	in	lb
	104	71	12	42	2200
	128	83	12	42	2200
FSV	152	95	12	42	2200
	150	71	53	42	2200

Basic capacity is 2200 lbs at 24" load center. Actual capacity is dependent upon specific truck configuration.

Minimum battery weight is 300 lbs.

Reference Toyota's FL Manual for complete specifications.

6BWS15

Mast Type	Maximum Fork Height	Overall Lowered Height	Free Lift	Minimum Base Leg (ID)	Capacity @ 24 in LC
V	in	in	in	in	lb
	104	71	12	42	3000
	128	83	12	42	3000
FSV	152	95	12	42	3000
	150	71	53	42	3000
	180	83	65	42	3000
	189	87	69	42	3000

Basic capacity is 3000 lbs at 24" load center. Actual capacity is dependent upon specific truck configuration.

Minimum battery weight is 950 lbs.

Reference Toyota's FL Manual for complete specifications

6BWS20

Mast Type	Maximum Fork Height	Overall Lowered Height	Free Lift	Minimum Base Leg (ID)	Capacity @ 24 in LC
V	in	in	in	in	lb
	100	71	6	42	4000
	124	83	6	42	4000
FSV	150	95	6	42	4000
	150	71	53	42	4000
	180	83	65	42	3600
	189	87	69	42	3500

Basic capacity is 4000 lbs at 24" load center. Actual capacity is dependent upon specific truck configuration.

Minimum battery weight is 950 lbs.

Reference Toyota's FL Manual for complete specifications.



Some product features described herein are optional. Please consult your dealer for specifications. Details of specifications and equipment are based on information available at time of printing and may change without notice.

00722-35191-802 8/02
Litho in U.S.A. (10M)

© 2002 Toyota Material Handling, U.S.A., Inc.
www.toyotaforklift.com